

ACTUAL SIZE

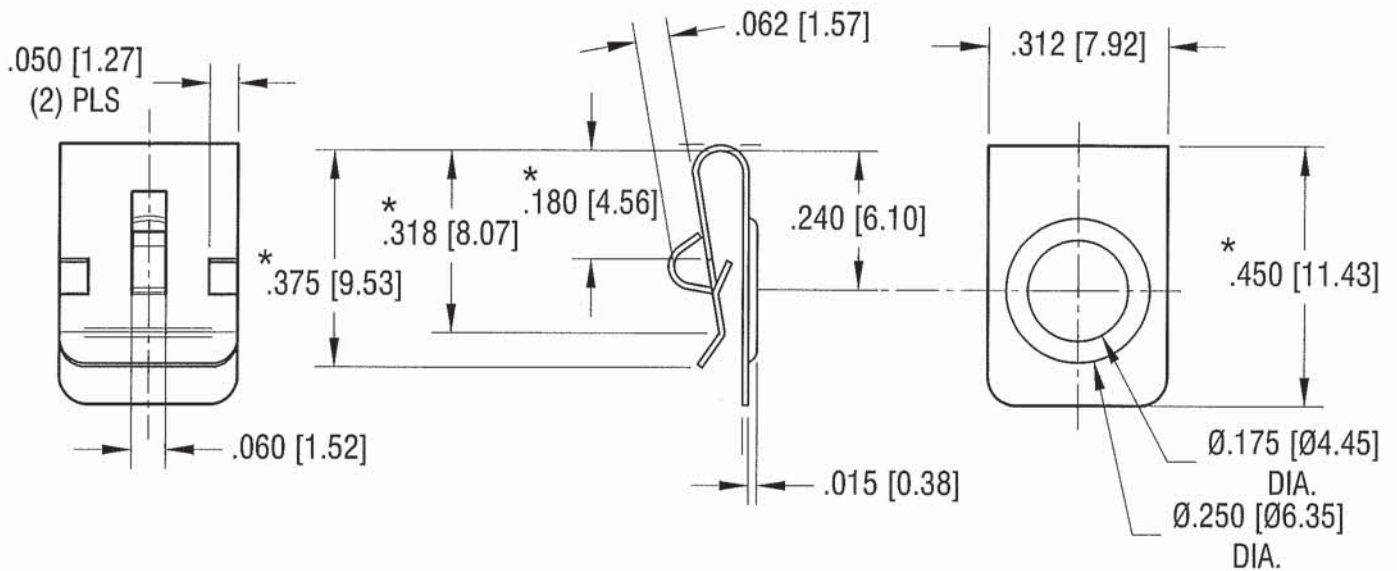
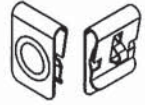

NOTE:

1. HEAT TREAT TO SPRING TEMPER.
2. DESIGNED TO CLIP OVER PANEL
FROM .060 [1.52] THRU .070 [1.78] TH'K
3. * DENOTES $\pm .015$ [± 0.38] TOLERANCE

KEYSTONE ELECTRONICS CORP.

www.keyelco.com • ASTORIA, N.Y. 11105-2017 • Tel (718) 956-8900

PART NAME

SINGLE 'A'-'AA' CONTACT

MATERIAL

.010 [0.25] TH'K ANNEALED SPRING STEEL

FINISH

NICKEL PLATE

DRN BY

BOONE

DATE

2.3.98

APP'D

SCALE

3X

TOLERANCES

INCH [MM]

DECIMAL $\pm .010$ [± 0.25]

ANGULAR $\pm 1^\circ$

UNLESS OTHERWISE SPECIFIED

CODE

C

DWG. NO.

228

DATE	DESCRIPTION	REV.
3.19.13	CHANGE AS PER ECN 13-028	H
8.14.12	ECN 12-104, CHANGE LOOP	G
3.23.07	CHANGE AS PER ECN 07-015	F