

LOC		DIST		REVISIONS				DATE	APPD
AF	50	P	F	ZONE	LTR	DESCRIPTION			
					E	REV PER 061A-0048-99	04JUN99	JR/DD	

1 CONTINUOUS STRIP ON REEL.

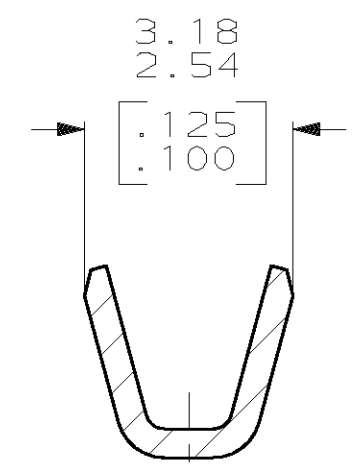

SECTION A-A
SCALE 10:1

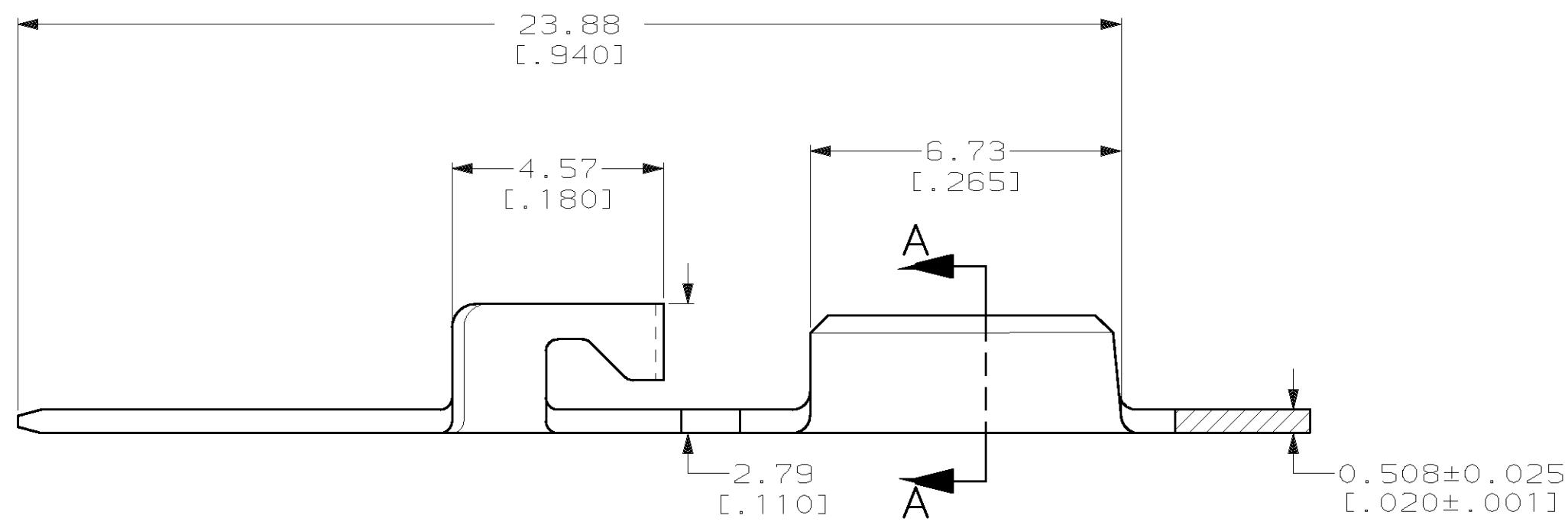
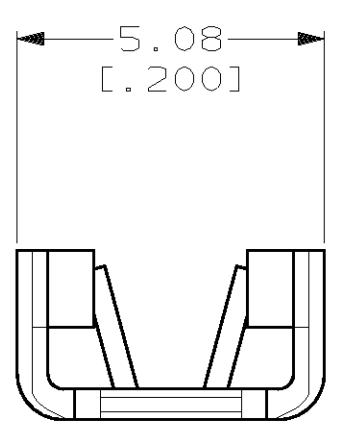
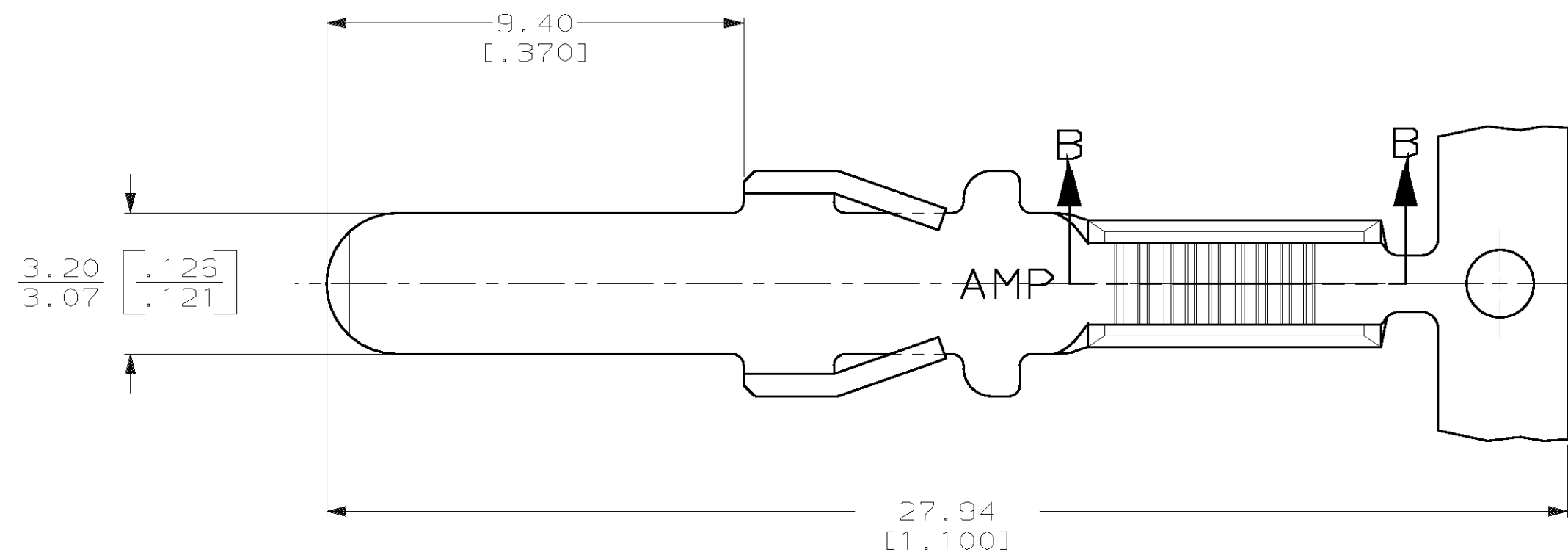
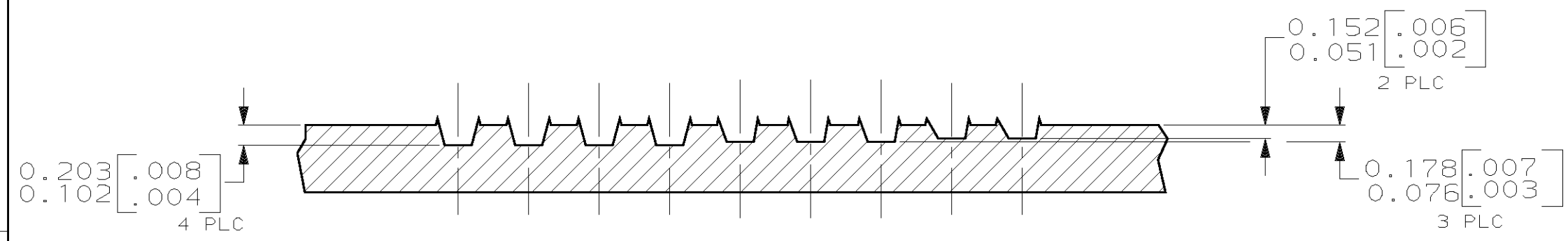

SECTION B-B
SCALE 25:1

400-1600 CMA RANGE	1217029-1
WIRE RANGE	PART NO

DO NOT SCALE PRINT. UNLESS SPECIFIED DIMENSIONS IN mm [INCHES] TOLERANCES ON: 2 PLC DEC ± 0.25 [.010] 3 PLC DEC ± - ANGLES ± -	DR 04/NOV/97 PHILLIP M FORTNEY	AMP Incorporated Harrisburg, PA 17105-3608	
	CHK 04/NOV/97 JEFF R RUTH		
MATERIAL 082 BRASS	APPD 04/NOV/97 DON DECKER	CONTACT, 3.18 [.125] BLADE, AMPLIVAR	
FINISH 0.002032 [.000080] MIN TIN PL PER MIL-T-10727	APPD 04/NOV/97 SUE WRIGHT		
THIS DRAWING IS A CONTROLLED DOCUMENT FOR AMP INCORPORATED. IT IS SUBJECT TO CHANGE AND THE CONTROLLING ENGINEERING ORGANIZATION SHOULD BE CONTACTED FOR THE LATEST REVISION.	PRODUCT SPEC -	NAME	
	APPLICATION SPEC -	SIZE	CAGE CODE
	WEIGHT -	SCALE	DRAWING NO
		8:1	00779
			G=1217029
			SHEET 1 OF 1